

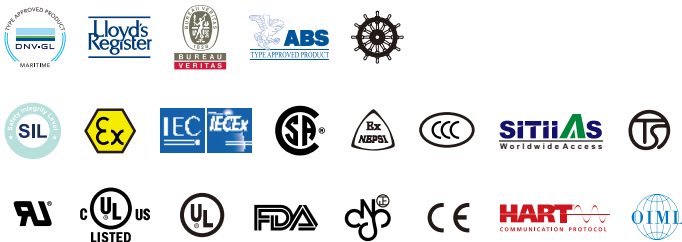

[www.fine-tek.com](http://www.fine-tek.com)

## Magnetostrictive Level Transmitter



# INTRODUCTION

The FineTek magnetostrictive level transmitter identifies the level of liquids and solutions with high precision and reliability.

This versatile sensor is ideal for continuous level measurement of a wide range of liquids. Application ranges from petrochemical industries, marine and shipping to food and beverage production.

The sensor has a loop power supply and provides direct analog or digital output to the user interface.

The FineTek magnetostrictive level sensor has proven itself due to its durability in a wide range of temperatures, pressures and operating conditions as well as its low maintenance nature.

## FEATURES

- Absolute positioning output and no calibration required after power failure.
- Stability and reliability.
- Easy installation without calibration & maintenance.
- Prompt response time, high resolution & high accuracy.
- Durable structure, dust-proof, withstands high pressure.
- Oil/water dual level indication.
- The Max. operation temp. is 195°C.
- EG36, 37, 60 adopted loop power structure for wire saving.
- Explosion-proof model available for hazardous environments.
- IP67(Enclosure)/IP69K(Probe).
- Support HART / RS485 and 4~20mA / voltage output.

## APPLICATION

- Liquefied natural gas.
- Crude oil, petroleum's and diesels.
- Chemical processing.
- Pharmaceuticals and medication.
- Food and beverages, breweries.
- Dams, water barriers, wastewater treatment.
- Power plants, marine and shipbuilding.
- Tooling or alignment position for processing machines.

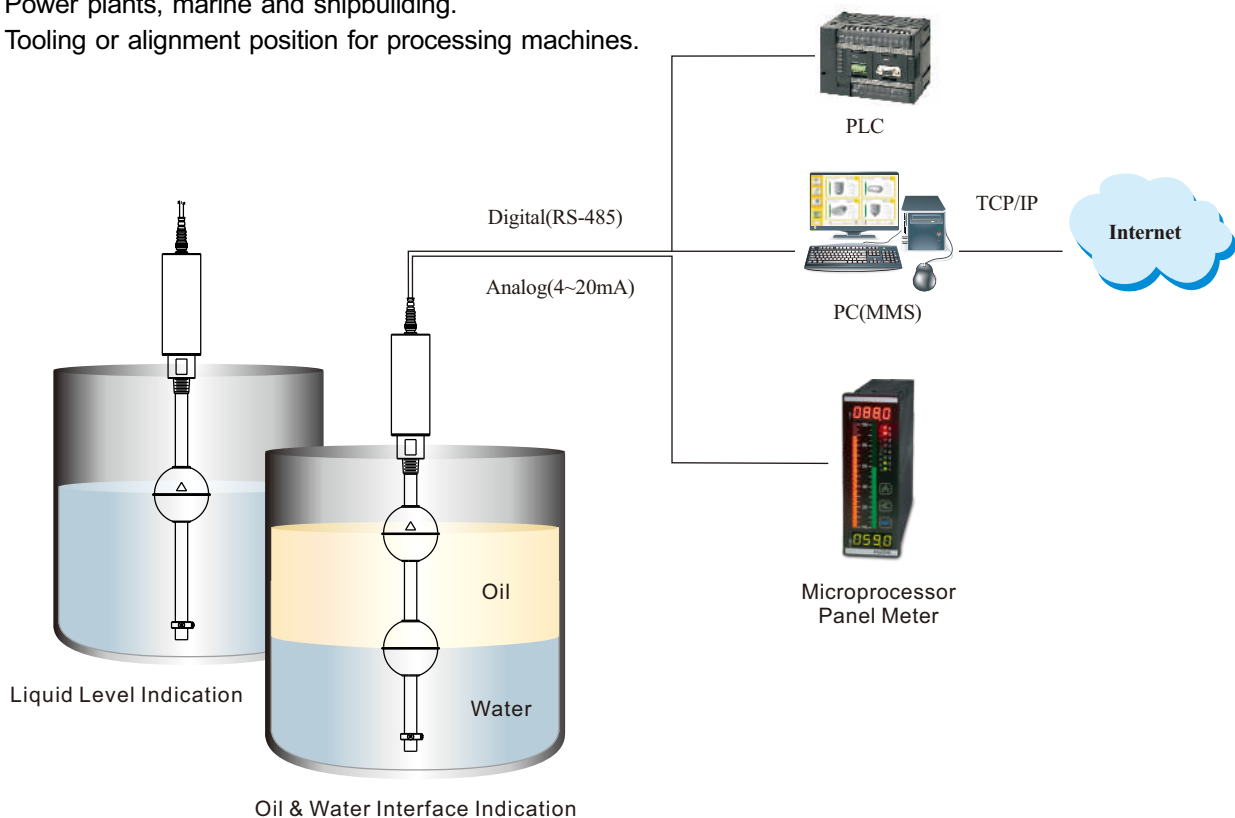

# OPERATING PRINCIPLE

The sensor mainly consists of magnetorestrictive wires sealed in a stem/rod and a permanent magnet sealed into a float that can move up and down the stem. Electrical current travels along the wires in the stem creating an axial magnetic field. When the float's and stem's magnetic field intersect, a torsional force is created with different height levels (see right).

The sensor measures the liquid level (D) by calculating the elapsed time between torsional forces. Using velocity and time, distance can be calculated. This action is timely and continuous. A change in float position will be detected promptly via signal output.

## CONVERSION FORMULA

The relation of  $\Delta D$  & 4~20mA output

$$\frac{IX-4}{(20-4)\text{mA}} = \frac{\Delta T - TX}{\Delta T} = \frac{DX}{\Delta D}$$

$$\Rightarrow IX = \frac{16DX}{\Delta D} + 4\text{mA} \text{ (The relative current)}$$

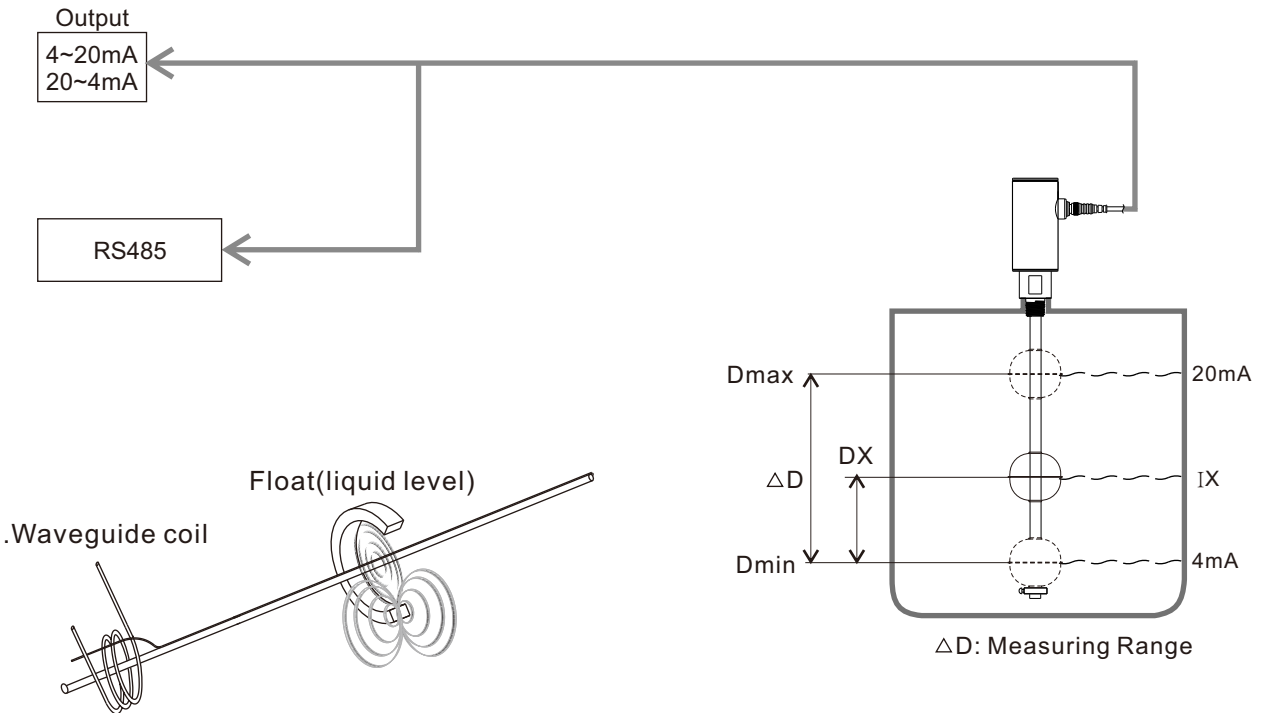
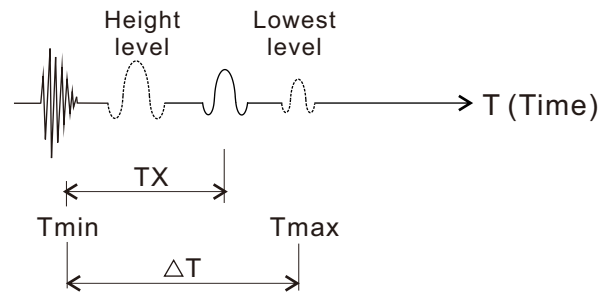

# EXPLOSION PROOF MODEL (2 Wire)

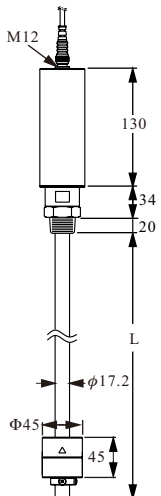
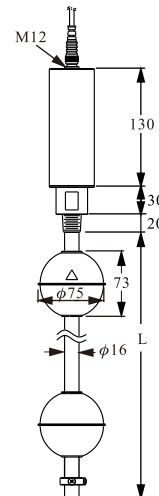

<b>Dimensions (Unit: mm)</b>	 <p style="text-align: center;">NEPSI Ex ia IIB T3~T6 Ga ATEX © II 1G Ex ia IIB T3~T6</p>	 <p style="text-align: center;">NEPSI Ex ia IIB T3~T6 Ga ATEX © II 1G Ex ia IIB T3~T6</p>
<b>Model No.</b>	<b>EG374 (Anti-Corrosion Model)</b>	<b>EG371 (Single/dual Float Model)</b>
<b>Application</b>	Two-wire loop power output, for acid/alkali corrosion liquids.	Two-wire loop power output, for single/dual level and interface measurement.
<b>Measuring range</b>	50~2000mm	50~5500mm
<b>Non-Linearity</b>	± 0.05% F.S. or ± 1.0mm (whichever is greater)	± 0.05% F.S. or ± 1.0mm (whichever is greater)
<b>Repeatability</b>	± 0.004% F.S.	± 0.004% F.S.
<b>Temp. coefficient</b>	± 100 ppm/°C	± 100 ppm/°C
<b>Operation pressure</b>	5 BAR(Max.)	30 BAR(Max.)
<b>Ambient temp.</b>	-40°C ~ 85°C	-40°C ~ 85°C
<b>Operation temp.</b>	-20°C ~ 80°C	-40°C ~ 125°C
<b>Temp. accuracy</b>	± 1°C	± 1°C
<b>Output</b>	4~20mA / 2 Wire	4~20mA / 2 Wire
<b>Max load (Ω)</b>	(VS-18)÷0.02 VS=Supply voltage	(VS-18)÷0.02 VS=Supply voltage
<b>Digital output</b>	RS485 / HART 7.3(option)	RS485 / HART 7.3(option)
<b>Response time</b>	16Hz	16Hz
<b>Power supply</b>	12~30V(4-wire), 18~30V(2-wire), 18~28V(Exp Llosion proof)	12~30V(4-wire) , 18~30V(2-wire), 18~28V(Exp Llosion proof)
<b>Housing material</b>	SUS304 (SUS316 option)	SUS304 (SUS316 option)
<b>Connection</b>	3/4"PT	1/2"PT
<b>Wetted material</b>	PP	SUS304
<b>Enclosure</b>	IP67 (Enclosure ) / IP69K(Probe)	IP67 (Enclosure ) / IP69K(Probe)

※ Must equipped with intrinsic safety barrier to form a standard intrinsically safe system (Ex ia), please refer to another catalog / brochure for TXX safety barrier.

※ The "4 Wire" type for EG36/ EG37 series: 2 wires are for power supply, the other 2 wires are for RS485 output. Please refer to wiring instruction in contents.

# EXPLOSION PROOF MODEL (2 Wire)

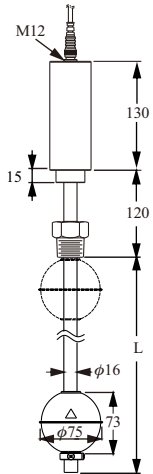
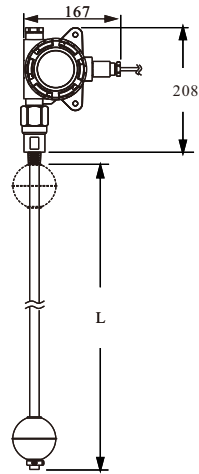

<b>Dimensions</b> (Unit: mm)	 <p style="text-align: center;">NEPSI Ex ia IIB T3-T6 Ga ATEX II 1G Ex ia IIB T3-T6</p>	 <p style="text-align: center;">NEPSI Ex ia IIB T3-T6 Ga ATEX II 1G Ex ia IIB T3-T6</p>
<b>Model No.</b>	<b>EG37A (Ex-proof High Temp. Model)</b>	<b>EG36 (Diaplay Model)</b>
<b>Application</b>	Two-wire loop power output, explosion-proof model for hazardous environment.	Two-wire loop power output, explosion-proof model with diaplay for hazardous environment.
<b>Measuring range</b>	50~5500mm	50~5500mm
<b>Non-Linearity</b>	±0.05% F.S. or ±1.0mm (whichever is greater)	50mm~4000mm ± 1mm 4000mm~5500mm ± 0.025% F.S.
<b>Repeatability</b>	± 0.004% F.S.	± 0.004% F.S.
<b>Temp. coefficient</b>	± 150 ppm/°C	± 100 ppm/°C
<b>Operation pressure</b>	30 BAR(Max.)	30 BAR(Max.)
<b>Ambient temp.</b>	-40°C ~ 85°C	-40°C ~ 85°C
<b>Operation temp.</b>	-40°C ~ 195°C	-40°C ~ 125°C
<b>Temp. accuracy</b>	± 1°C	± 1°C
<b>Output</b>	4~20mA / 2 Wire	4~20mA / 2 Wire
<b>Max load (Ω)</b>	$(VS-18) \div 0.02$ VS=Supply voltage	$(VS-16) \div 0.02$ VS=Supply voltage
<b>Digital output</b>	RS485/HART 7.3( option)	RS485/HART 7.3( option)
<b>Response time</b>	16Hz	16Hz
<b>Power supply</b>	12~30V(4-wire), 18~30V(2-wire), 18~28V(Exp Losion proof)	12~30V(4-wire) ,16~30V(2-wire), 16~28V(Exp Losion proof)
<b>Housing material</b>	SUS304 (SUS316 option)	Aluminum
<b>Connection</b>	1/2"PT	1/2"PT
<b>Wetted material</b>	SUS304	SUS304
<b>Enclosure</b>	IP67 (Enclosure ) / IP69K(Probe)	IP67 (Enclosure ) / IP69K(Probe)

※ Must equipped with intrinsic safety barrier to form a standard intrinsically safe system (Ex ia), please refer to another catalog / brochure for TXX safety barrier.

※ The "4 Wire" type for EG36/ EG37 series: 2 wires are for power supply, the other 2 wires are for RS485 output. Please refer to wiring instruction in contents.

# EG50 (4 Wire)

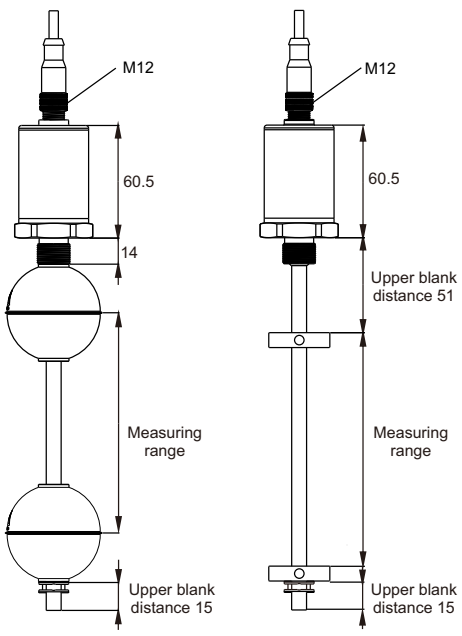
<p><b>Dimensions</b> (Unit: mm)</p>	
<p><b>Model No.</b></p>	<p><b>EG50</b></p>
<p><b>Application</b></p>	<p>Four wire output</p>
<p><b>Measuring range</b></p>	<p>50~1000mm</p>
<p><b>Linearity</b></p>	<p>Range of more than 500mm, error <math>\pm 0.1\%</math> F.S Range of 500mm below the error of <math>\pm 500\mu\text{m}</math></p>
<p><b>Repeatability</b></p>	<p><math>\pm 0.005\%</math> F.S.</p>
<p><b>Temp. coefficient</b></p>	<p><math>\pm 100</math> ppm/<math>^{\circ}\text{C}</math></p>
<p><b>Operation pressure</b></p>	<p>30 BAR(Max.)</p>
<p><b>Ambient temp.</b></p>	<p><math>-40^{\circ}\text{C} \sim 85^{\circ}\text{C}</math></p>
<p><b>Operation temp.</b></p>	<p><math>-40^{\circ}\text{C} \sim 125^{\circ}\text{C}</math></p>
<p><b>Temp. accuracy</b></p>	<p><math>\pm 0.5^{\circ}\text{C}</math></p>
<p><b>Output</b></p>	<p>4~20mA / 20~4mA</p>
<p><b>Max load (<math>\Omega</math>)</b></p>	<p><math>(\text{VS}-18) \div 0.02</math> VS=Supply voltage</p>
<p><b>Digital output</b></p>	<p>RS485 (Option)</p>
<p><b>Response time</b></p>	<p>1KHz</p>
<p><b>Power supply</b></p>	<p>18~30V</p>
<p><b>Housing material</b></p>	<p>SUS304 (SUS316 Option)</p>
<p><b>Connection</b></p>	<p>M18x1.5</p>
<p><b>Wetted material</b></p>	<p>SUS304(SUS316 Option)</p>
<p><b>Enclosure</b></p>	<p>IP67 (Enclosure) / IP69K (Probe)</p>

※ The output with 2 sets of 4~20mA analog output is available for EG50 series.

## EG60 (2 Wire / 4 Wire)

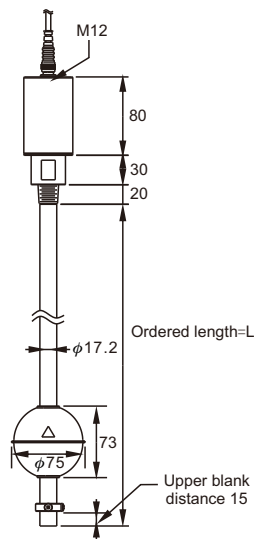
<b>Dimensions (Unit: mm)</b>		
<b>Model No.</b>	EG60 Two wire	EG60 Four wire
<b>Application</b>	Two wire loop Power output, comply with HART demand.	Four wire output
<b>Measuring range</b>	50~5500mm	50~2500mm
<b>Linearity</b>	(50~2000mm), 1mm (2001~5500mm), 0.05%F.S	(50~500mm), 0.1mm (50~500mm), 0.2mm (50~500mm), 0.5mm (500~2500mm), 0.02%F.S (500~2500mm), 0.05%F.S (500~2500mm), 0.1%F.S
<b>Repeatability</b>	± 0.002% F.S.	
<b>Temp. coefficient</b>	± 100 ppm/°C	
<b>Operation pressure</b>	30 BAR(Max.)	
<b>Ambient temp.</b>	-40°C~ 85°C	
<b>Operation temp.</b>	-40°C ~ 125°C (Std. model) , -40~195°C (High temp. model)	
<b>Temp. accuracy</b>	± 0.5°C	
<b>Output</b>	4~20mA/ 20~4mA	0~10V, 10~0V, 0~5V, 5~0V, 4~20mA, 20~4mA
<b>Max load (Ω)</b>	$(V_S - 18) \div 0.02$ $V_S = \text{Supply voltage}$	500W
<b>Digital output</b>	RS485, HART (Option)	RS485 (Option)
<b>Response time</b>	16Hz	250Hz
<b>Power supply</b>	18~30V	
<b>Housing material</b>	SUS304 (SUS316 Option)	
<b>Connection</b>	1/2"PT	
<b>Wetted material</b>	SUS304	
<b>Enclosure</b>	IP67 (Enclosure) / IP69K (Probe)	

# HOUSING OPTIONS

## Mapping table of enclosure

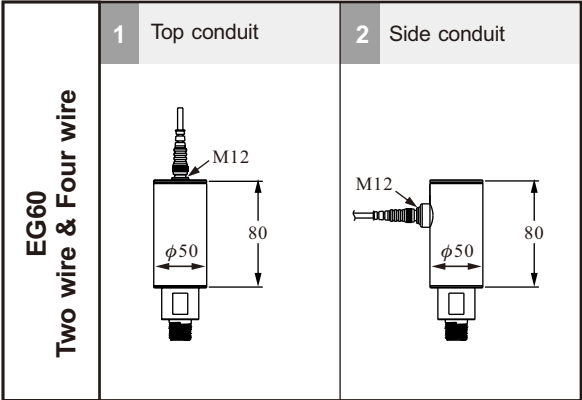
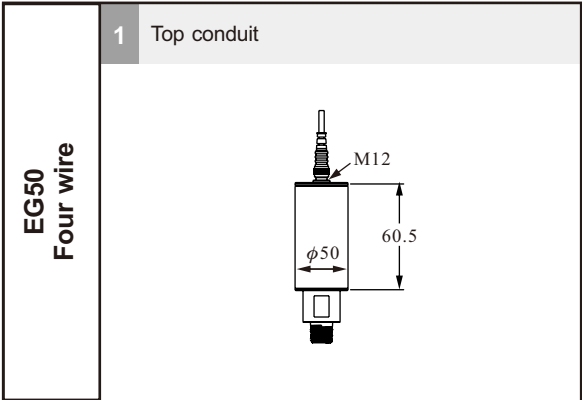
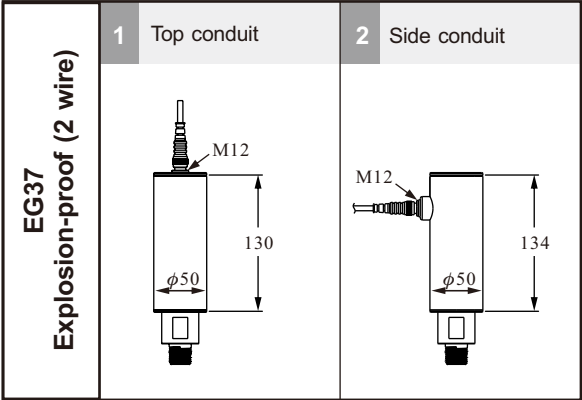

※ Standard model cable length is 2m.

## External structure-Double float

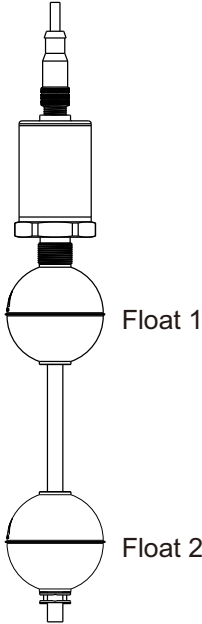

# FLOAT SPECIFICATIONS

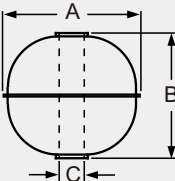
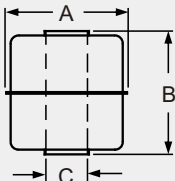
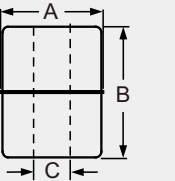
Model	Model Number	Dimensions ( $\phi A \times B \times \phi C$ mm)	S.G.	Max. Pressure (kg/cm <sup>2</sup> )	Material	Stem Size
	<b>S5</b>	75x73x20.5	E>0.7	30	SUS 304 / 316	$\phi 16$
	<b>S4</b>	52x52x15	E>0.75	30	SUS 316	$\phi 12.7$
	<b>SD</b>	52x52x15	E>0.9	30	SUS 316	$\phi 12.7$
	<b>SE</b>	75x73x20.5	E>0.9	20	SUS 304 / 316	$\phi 16$
	<b>A1</b>	32x69x10.9	E>0.75	10	SUS 316 / 316L	$\phi 8$
	<b>AA</b>	32x69x10.9	E>0.9	10	SUS 316 / 316L	$\phi 8$
	<b>S3</b>	45x55x15	E>0.7	12	SUS 316	$\phi 12.7$
	<b>SC</b>	45x55x15	E>0.9	12	SUS 316	$\phi 12.7$
	<b>F3</b>	45x45x20	E>0.65	5	PP in Grey	$\phi 18$ (coating)
	<b>FC</b>	45x45x20	E>0.9	5	PP in Grey	$\phi 18$ (coating)
	<b>P3</b>	48x45x18.5	E>0.6	5	PP in Black	$\phi 17.2$ (coating)
	<b>PC</b>	48x45x18.5	E>0.9	5	PP in Black	$\phi 17.2$ (coating)
	<b>NB</b>	48x46x15.6	E>0.5	30	NBR in Black	$\phi 12.7$
	<b>ND</b>	48x46x15.6	E>0.9	30	NBR in Black	$\phi 12.7$
	<b>NC</b>	48x46x20	E>0.5	30	NBR in Black	$\phi 16$
<b>NE</b>	48x46x20	E>0.9	30	NBR in Black	$\phi 16$	

※ S.G(E):specific gravity

※ Probe diameter must be smaller then float's hole diameter.

# WIRING

**When RS485(ModBus)is applied,Loop power only as power.**

**EG37 / EG60 (2 wire):**

1. Single / Double float +RS485

Loop Power 24Vdc ± 10%

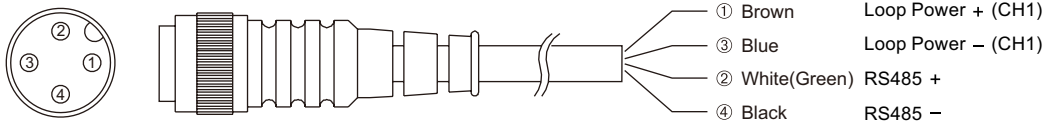

2. Single / Double float +HART

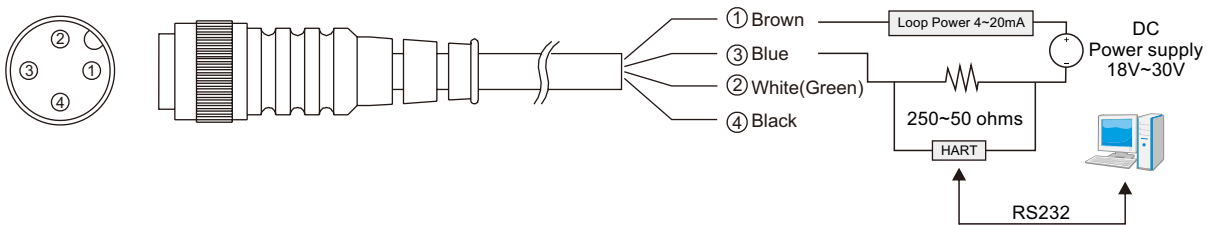

**EG36:**

Single / Double float +RS485

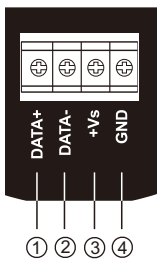

- ① D+: RS485 +
- ② D -: RS485 -
- ③ V +: Loop Power +
- ④ V -: Loop Power -

# CUSTOMIZED STEM LENGTHS ARE AVAILABLE

Note the difference between ordered length and actual measurable stem length below.

(2m below) = Actual measurable length (X) = Ordered length (L) - 52mm - 15mm, adopted stem  $\phi 12.7$

(2m above) = Actual measurable length (X) = Ordered length (L) - 73mm - 15mm, adopted stem  $\phi 16$

(2m below) = Actual measurable length (X) = Ordered length (L) - 45mm - 25mm, adopted stem  $\phi 17.2$

## Below 2m, stem $\phi 12.7$

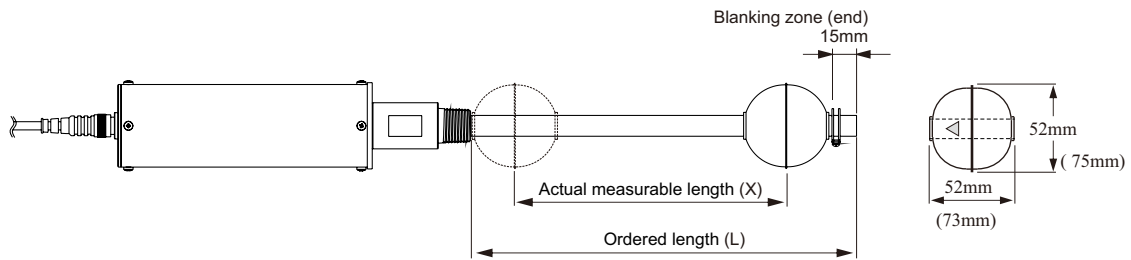

## Above 2m, stem $\phi 16$

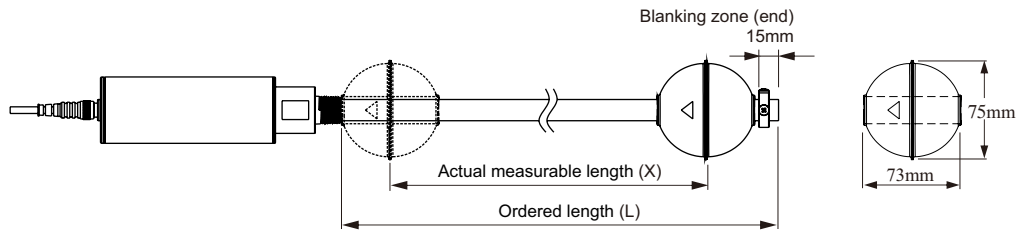

## Below 2m, stem $\phi 12.7$ , with PP coating to $\phi 17.2$

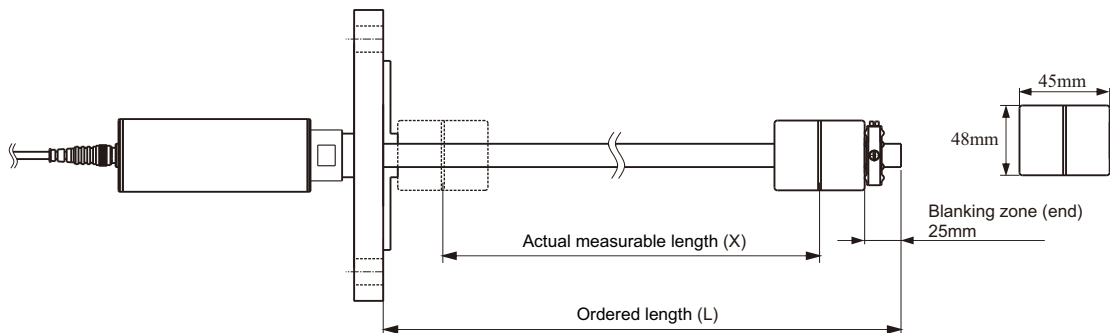

# INSTALLATION

1. Loop power 24Vdc  $\pm$ 10%
2. The product is calibrated before shipment and should be sufficient to meet user needs.
3. Do not bend the stem, put pressure on it or force it in any manner.
4. For best results, use the included float only.
5. When the mounting hole is large enough, guide the stem and float through the hole to install.
6. If the hole is NOT large enough, remove float, install the stem and assemble float from inside the container.
7. When assembling the float onto the stem, the float's direction mark should face the housing.
8. Ensure the float stopper is fixed firmly.
9. If the stem is bent and can not work, it needs to be returned to the factory for calibration.
11. Bubble wrap/foam packaging is necessary to ensure safety during transportation.
12. Unnecessary opening of housing may affect accuracy.

## Removing the float

Step 1:  
Loosen the stopper at stem end

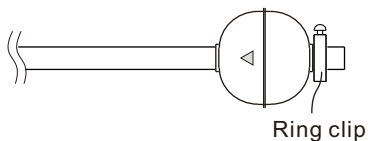

Step 2:  
Take off the float

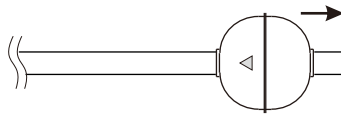

Step 3:  
Install the sensor onto the tank,  
and tighten the connection

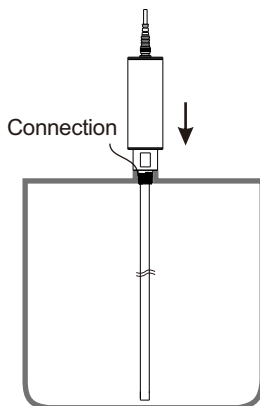

Step 4:  
Assemble the float onto the stem  
and tighten the connection the  
housing. Note the direction of float

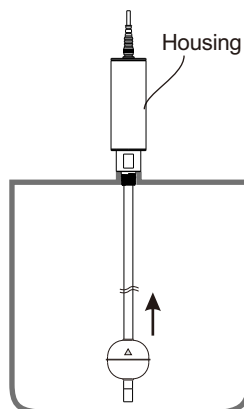

Step 5:  
Firmly fasten the stopper

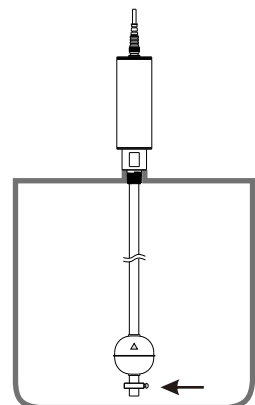

# MODEL NUMBER / ORDER CODE COMPARISON TABLE

Model Number	Order Code
EG374 Anti-Corrosion type	EGX1001B-B1
EG371 Ex- Proof type	EGX1001B-A1
EG37A Ex- Proof High temperature type	EGX1021B-A1
EG36 Display type	EGX3001B-A1
EG36 High temperature display type	EGX3021B-A1
EG50	EGX5 □□□□-□□
EG60	EGX6 □□□□-□□

## ACCESSORIES

### Cable Conduit - Ex d IIC

Material: Washer — NBR

Body— Copper alloy(3/4"NPT)  
Nickel plated(1/2"NPT)

HP415-A23100MH01(29-1104)

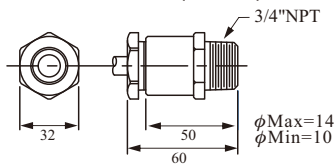

HP415-A23000MG01(29-1108)

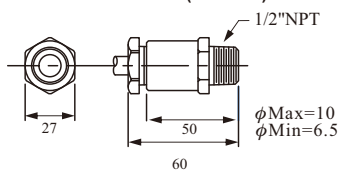

# ORDER INFORMATION

EGX <sup>04</sup> <sup>05</sup> <sup>06</sup> <sup>07</sup> <sup>08</sup> - <sup>09</sup> <sup>10</sup> <sup>11</sup> <sup>12</sup> <sup>13</sup> <sup>14</sup> <sup>15</sup> <sup>16</sup> <sup>17</sup> <sup>18</sup> <sup>19</sup> <sup>20</sup> <sup>21</sup> <sup>22</sup> <sup>23</sup> <sup>24</sup> <sup>25</sup> <sup>26</sup> <sup>27</sup> <sup>28</sup> <sup>29</sup> <sup>30</sup> <sup>31</sup> <sup>32</sup> <sup>33</sup>

**04 Version**

- 1: 132mm (EG37)
- 3: Display type (EG36)
- 5: EG50

**05 06 Model**

- 00: Standard
- 02: Hi-temperature
- 03: Sanitary

**07 08 Certification**

- 00: None
- 1B: ATEX-Exia
- 7B: NEPSI-Exia

**09 10 Sensor Type**

- A1: Probe type
- B1: Anti-Corrosion probe type

**Connection**

**11 12**

- Flange item
- AI : 3A
- AK: JIS-FF
- AN: ANSI-RF
- AS: DIN-FF

**13 14**

- A5: 1/2"
- A7: 3/4"
- A8: 1"
- B1: 1-1/2"
- B2: 2"
- B4: 2-1/2"
- D7: DN20
- D8: DN25
- D9: DN32
- E1: DN40
- E2: DN50
- E3: DN65
- 19: M18

**15 16**

- 01: PT male
- 03: PF male
- 07: NPT male
- 15: UNF male
- 40: 5 kg/cm<sup>2</sup>
- 42: 10 kg/cm<sup>2</sup>
- 48: 150 Lbs
- 49: 300 Lbs
- 57: PN10
- 58: PN16
- 82: (P)1.5 male

(Next page)

EGX <sup>04</sup> <sup>05</sup> <sup>06</sup> <sup>07</sup> <sup>08</sup> - <sup>09</sup> <sup>10</sup> <sup>11</sup> <sup>12</sup> <sup>13</sup> <sup>14</sup> <sup>15</sup> <sup>16</sup> <sup>17</sup> <sup>18</sup> <sup>19</sup> <sup>20</sup> <sup>21</sup> <sup>22</sup> <sup>23</sup> <sup>24</sup> <sup>25</sup> <sup>26</sup> <sup>27</sup> <sup>28</sup> <sup>29</sup> <sup>30</sup> <sup>31</sup> <sup>32</sup> <sup>33</sup>

**<sup>17</sup> <sup>18</sup> Probe diameter**

- 1F:  $\phi$ 8mm
- 1G:  $\phi$ 9.5mm
- 1H:  $\phi$ 10mm
- 2A:  $\phi$ 12.7mm
- 2C:  $\phi$ 16.0mm
- 2D:  $\phi$ 17.2mm

**<sup>19</sup> <sup>20</sup> Probe material**

- MA: SUS 304
- MB: SUS 316
- MC: SUS 316L
- 18: PP coating

**<sup>21</sup> <sup>22</sup> Float 1**

- |                       |                        |
|-----------------------|------------------------|
| 00: None              |                        |
| S3: 45*55*15(E>0.7)   | P3: 48*45*18.5(E>0.6)  |
| SC: 45*55*15(E>0.9)   | PC: 48*45*18.5(E>0.9)  |
| S4: 52*52*15(E>0.75)  | NC: 48*46*20(E>0.5)    |
| SD: 52*52*15(E>0.9)   | NE: 48*46*20(E>0.9)    |
| NB: 48*46*15.6(E>0.5) | S5: 75*73*20(E>0.7)    |
| ND: 48*46*15.6(E>0.9) | SE: 75*73*20.5(E>0.9)  |
| F3: 45*45*20(E>0.65)  | A1: 32*69*10.9(E>0.75) |
| FC: 45*45*20(E>0.9)   | AA: 32*69*10.9(E>0.9)  |

**<sup>23</sup> <sup>24</sup> Float 2**

- |                       |                       |
|-----------------------|-----------------------|
| 00: None              |                       |
| SC: 45*55*15(E>0.9)   | ND: 48*46*15.6(E>0.9) |
| SD: 52*52*15(E>0.9)   | NE: 48*46*20(E>0.9)   |
| FC: 45*45*20(E>0.9)   | SE: 75*73*20.5(E>0.9) |
| PC: 48*45*18.5(E>0.9) | AA: 32*69*10.9(E>0.9) |

(Next page)

EGX <sup>04</sup> <sup>05</sup> <sup>06</sup> <sup>07</sup> <sup>08</sup> <sup>09</sup> <sup>10</sup> <sup>11</sup> <sup>12</sup> <sup>13</sup> <sup>14</sup> <sup>15</sup> <sup>16</sup> <sup>17</sup> <sup>18</sup> <sup>19</sup> <sup>20</sup> <sup>21</sup> <sup>22</sup> <sup>23</sup> <sup>24</sup> <sup>25</sup> <sup>26</sup> <sup>27</sup> <sup>28</sup> <sup>29</sup> <sup>30</sup> <sup>31</sup> <sup>32</sup> <sup>33</sup>

**25 Digital output 1**

- 0: None
- A: 4~20mA
- B: 20~4mA
- L: 4~20mA x 2 sets
- M: 20~4mA x 2 sets
- ※ " L ". " M " options are only available with EG50

**26 Digital output 2**

- 0: None
- B: RS-485
- C: RS485 (RS485 with temperature x 1pcs)
- E: HART
- F: HART 7.3 with temperature sensor x 1pcs
- ※ Only RS485 can be selected for EG50.

**27 Housing**

- A: Top conduit
- B: Side conduit

**28 Response time**

- A: 16 Hz (EG36 , EG37)
- C: <1KHz (EG50)

**29 Material and surface roughness**

- 0: None
- A: Ra < 0.3
- B: Ra < 0.5
- C: Ra < 0.8

**30 31 32 33 Length**

Code	Probe Length
0050~5500	50~5500mm

※ Max. probe length for EG50 is 1000m.



EGX  <sup>04</sup>  <sup>05</sup>  <sup>06</sup> 00 -  <sup>09</sup>  <sup>10</sup>  <sup>11</sup>  <sup>12</sup>  <sup>13</sup>  <sup>14</sup>  <sup>15</sup>  <sup>16</sup>  <sup>17</sup>  <sup>18</sup>  <sup>19</sup>  <sup>20</sup>  <sup>21</sup>  <sup>22</sup>  <sup>23</sup>  <sup>24</sup>  <sup>25</sup>  <sup>26</sup>  <sup>27</sup>  <sup>28</sup>  <sup>29</sup>  <sup>30</sup>  <sup>31</sup>  <sup>32</sup>  <sup>33</sup>  <sup>34</sup>  <sup>35</sup>

**04 Version**  
6: EG60

**05 06 Model**  
00: Standard  
02: Hi-temperature  
03: Sanitary

**09 10 Probe type**  
A1: Probe type  
B1: Anti-Corrosion probe type

(Next page)

**Connection**

**11 12**  
Flange item  
AI : 3A  
AK: JIS-FF  
AN: ANSI-RF  
AS: DIN-FF  
  
Thread item  
AA: JIS  
AC: ANSI

**13 14**  
A5: 1/2"  
A7: 3/4"  
A8: 1"  
B1: 1-1/2"  
B2: 2"  
B4: 2-1/2"  
D7: DN20  
D8: DN25  
D9: DN32  
E1: DN40  
E2: DN50  
E3: DN65

**15 16**  
00: None  
01: PT male  
03: PF male  
07: NPT male  
40: 5 kg/cm<sup>2</sup>  
42: 10 kg/cm<sup>2</sup>  
48: 150 Lbs  
49: 300 Lbs  
57: PN10  
58: PN16





# Global Network



## ■ Head Quarter

### ● Taiwan

**FineTek Co., Ltd. - Taipei Head Quarter**   
 No.16, Tzuchiang St., Tucheng Industrial Park  
 New Taipei City 236, Taiwan  
 TEL: 886-2-2269-6789  
 FAX: 886-2-2268-6682  
 EMAIL: info@fine-tek.com

## ■ North America

### ● California, U.S.

**Aplus Finetek Sensor Inc. - US Office**  
 355 S. Lemon Ave, Suite D  
 Walnut, CA 91789  
 TEL: 1 909 598 2488  
 FAX: 1 909 598 3188  
 EMAIL: info@aplusfine.com

## ■ Europe

### ● Germany

**FineTek GmbH - Germany Office**  
 Bei den Kämpen 26  
 21220 Seevetal-Ramelsloh, Germany  
 TEL: +49-(0)4185-8083-12  
 FAX: +49-(0)4185-8083-80  
 EMAIL: info@fine-tek.de

## ■ Asia

### ● China

**Fine automation Co., Ltd. - Shanghai Factory**   
 No.451 DuHui Rd, MinHang District, Shanghai,  
 China 201109  
 TEL: 86-21-6490-7260  
 EMAIL: info.sh@fine-tek.com

### ● Singapore

**FineTek Pte Ltd. - Singapore Office**  
 37 Kaki Bukit Place, Level 4 Singapore 416215  
 TEL: 65-6452-6340  
 EMAIL: info.sg@fine-tek.com

### ● Indonesia

**PT. FineTek Automation Indonesia - Indonesia Office**   
 PERGUDANGAN TUNAS BITUNG  
 Jl. Raya Serang KM. 13,8, Blok C3 No. 12&15, Bitung Cikupa,  
 Tangerang 15710  
 TEL: 62 (021)-2958-1688  
 EMAIL: info.id@fine-tek.com

### ● Müttec Instruments GmbH - Germany Office

Bei den Kämpen 26  
 21220 Seevetal-Ramelsloh, Germany  
 TEL: +49-(0)4185-8083-0  
 FAX: +49-(0)4185-8083-80  
 EMAIL: muetec@muetec.de



Distributor: